

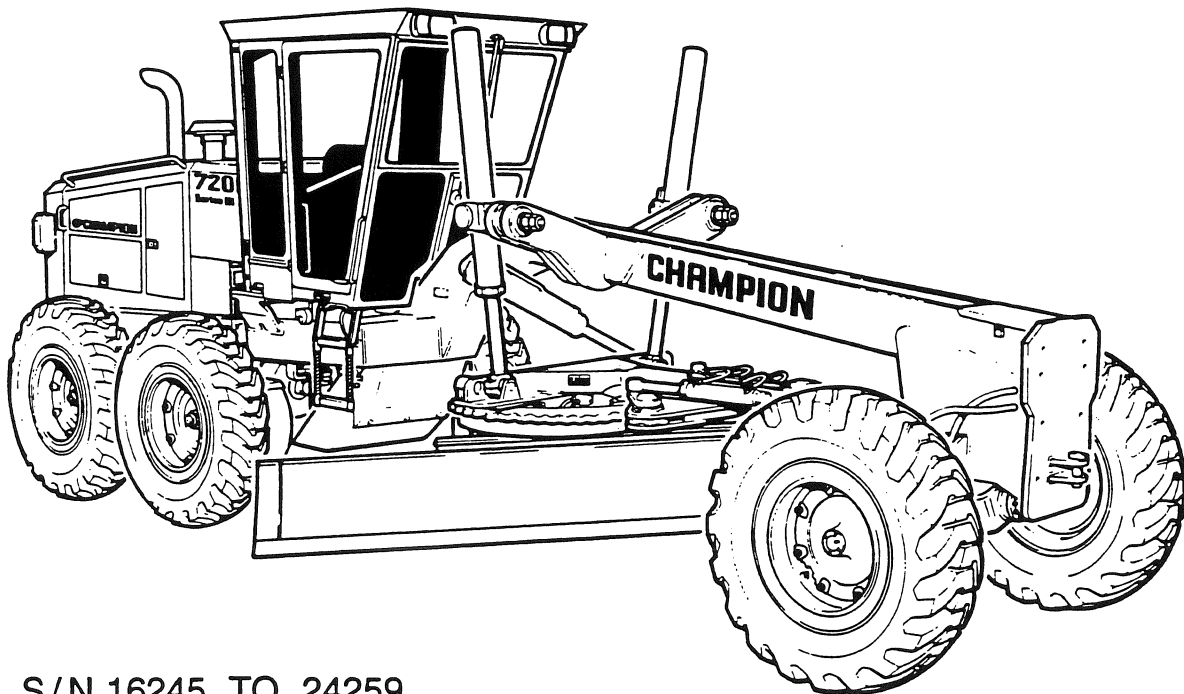

8400 Electrical Troubleshooting Guide



S/N 16245 TO 24259

Error Code Table

CODE	MALFUNCTION	CODE	MALFUNCTION
1.0	Electric power is below 9.5 Vdc	3.0	Short circuit, solenoid 2 (B)
2.0	Open circuit, solenoid 2 (B)	3.1	Short circuit, solenoid 3 (R)
2.1	Open circuit, solenoid 3 (R)	3.3	Short circuit, solenoid 6 (L)
2.3	Open circuit, solenoid 6 (L)	3.4	Short circuit, solenoid 7 (H)
2.4	Open circuit, solenoid 7 (H)	3.5	Short circuit, solenoid 5 (D)
2.5	Open circuit, solenoid 5 (D)	3.6	Short circuit, solenoid 1 (A)
2.6	Open circuit, solenoid 1 (A)	4.0	Forward/Neutral input error
2.7	No power to solenoid circuits	4.1	Reverse/Neutral input error
		4.2*	Controller restart error
		4.4**	Forward/Reverse input error

All Error Codes are common between 1.7, 1.8, 2.7 and 6.0 software except:

- * Found only in 1.8 AND 2.7 software
- ** Found only in 2.7 software

This guide only applies to 12Vdc running electrical systems. The transmission controller and solenoids installed in graders with 24Vdc start but 12Vdc charging systems operate on 12Vdc.

Please consult Champion for information about graders equipped with a total 24Vdc electrical system.

NOTE: The information contained in this 8400 Electrical Trouble Shooting Guide is for reference only. Refer to the Champion 700 Series Shop Manual for proper safety and service procedures BEFORE performing any service procedure.

Champion Road Machinery cannot anticipate all circumstances that may arise. Thus this chart is only a guide to trouble shooting the 8400 Electrical System.

Error Code Explanation Chart

CODE SERIES	DESCRIPTION
1.0	<p>Low system voltage Check:</p> <ul style="list-style-type: none"> - Applied voltage at Controller (pin #11 on round connector or pin 'F' on flat 6 terminal connector) - Charging system - For proper grounding of Controller
2.0 - 2.6	<p>Open circuit or short to ground in applicable Solenoid circuit *Check for continuity at:</p> <ul style="list-style-type: none"> - Solenoid coil - Solenoid wiring harness - Controller connection
2.7	<p>No voltage in 15 amp circuit (Transmission Solenoid) Check for continuity at:</p> <ul style="list-style-type: none"> - Circuit breaker - Transmission relay - Normally closed terminals on micro switch when in Forward or Reverse - At each Solenoid - At Transmission harness connector to Controller
3.0 - 3.6	<p>Short circuit in applicable Solenoid circuit Check:</p> <ul style="list-style-type: none"> - Solenoid coil resistance - Solenoid wiring harness and coil resistance - Controller connection for corrosion
4.0 - 4.1	<p>Forward or Reverse input error Check:</p> <ul style="list-style-type: none"> - Neutral start micro switch operation - Magnets for proper clearance and adjustment
4.2	<p>Neutral input error</p> <ul style="list-style-type: none"> - F-N-R lever was left in gear when unit was shut off, or shifted during start-up sequence, or controller experienced a momentary power or ground loss - Shift F-N-R lever to Neutral - Check power supply to pin #11 on main supply harness on round connector or pin 'F' on flat 6 terminal connector
4.4	<p>Internal Forward or Reverse signal switch malfunction</p> <ul style="list-style-type: none"> - Obtainable only when leaving Neutral - Replace Controller

* When using an ohmmeter, ensure the battery isolation switch is turned OFF.

Grader will not Operate

GRADER WILL NOT OPERATE
when either forward or reverse is selected

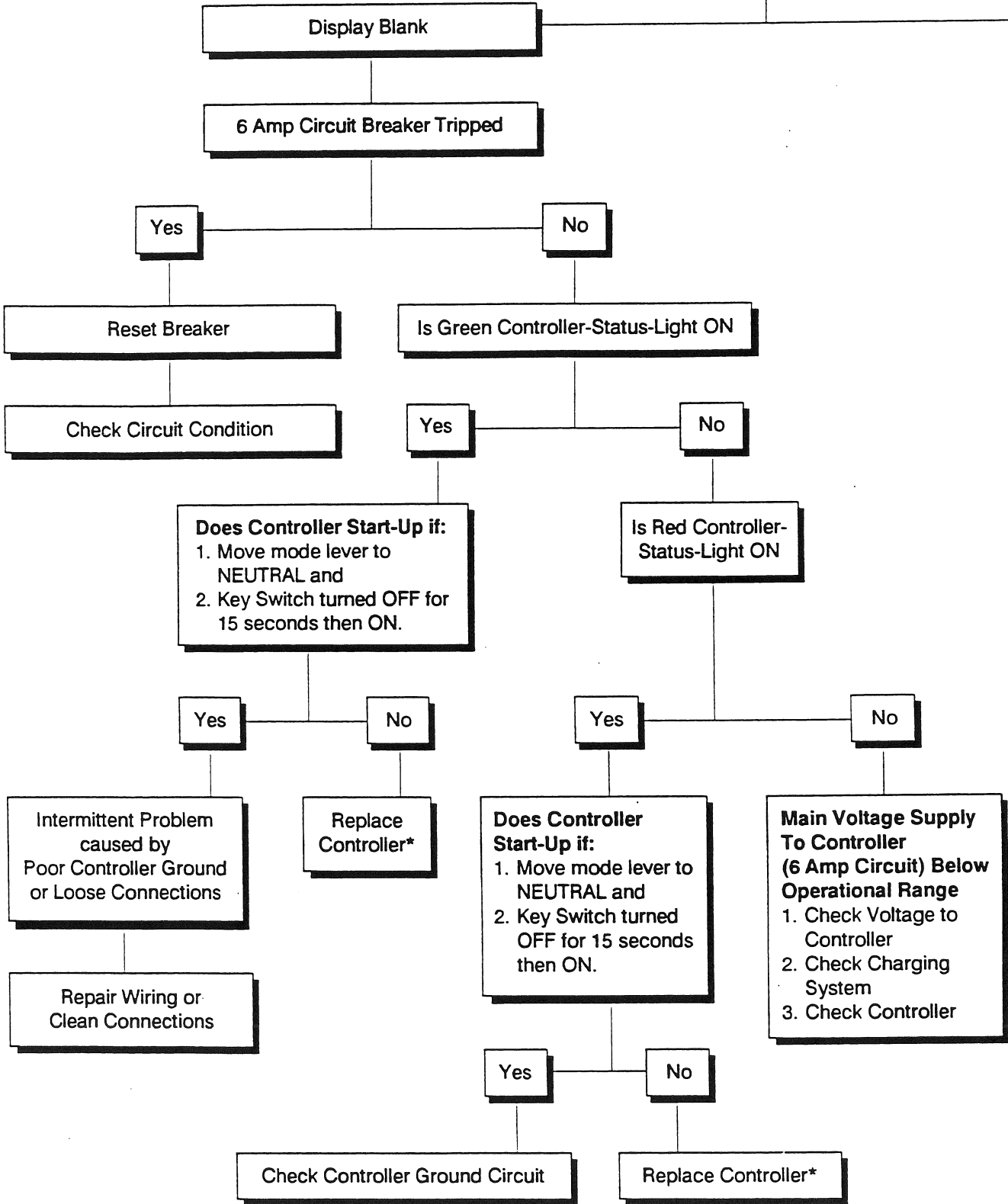

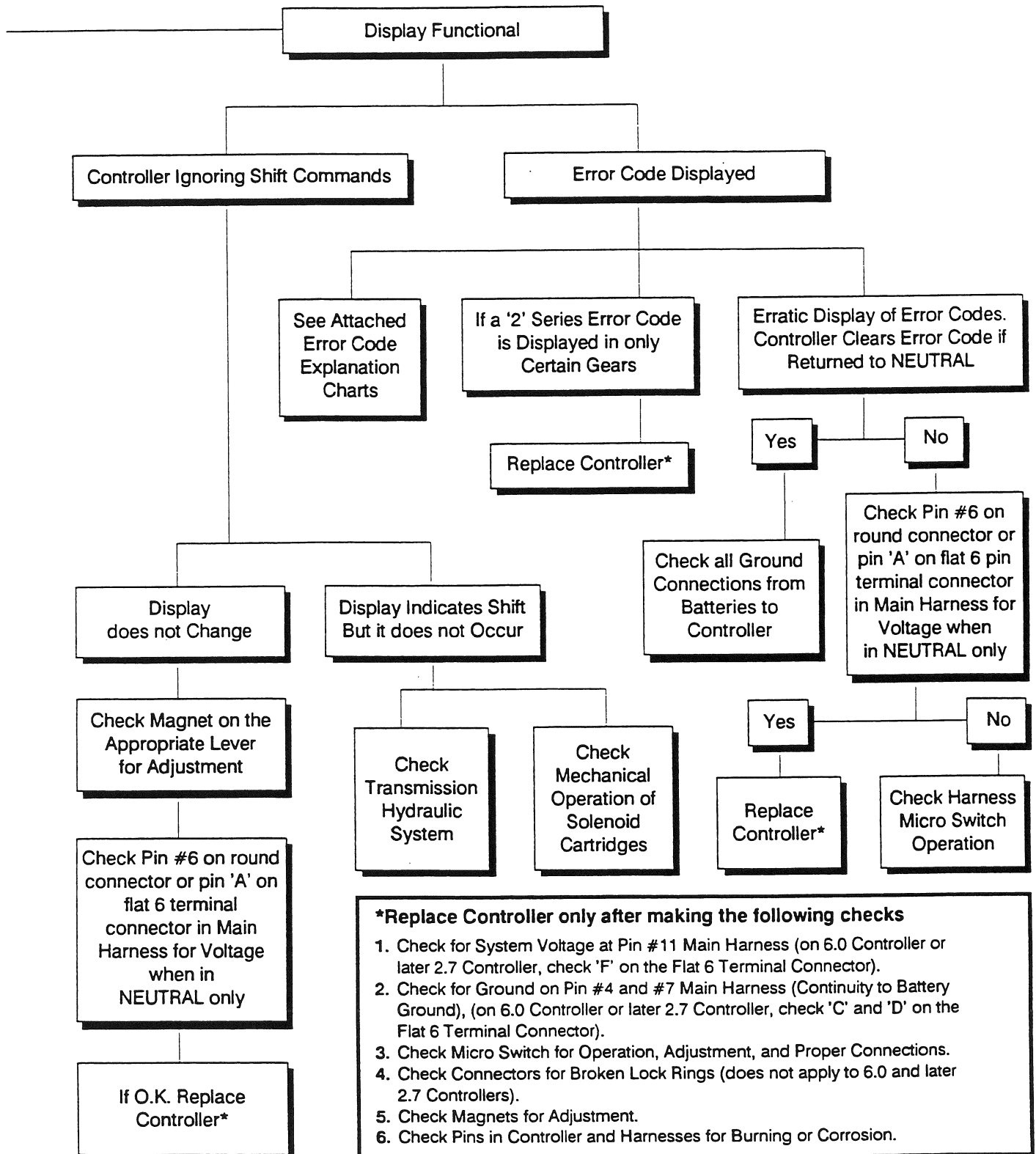

Electrical Schematic - Gearco Model 8400 Transmission Up to S/N 21449

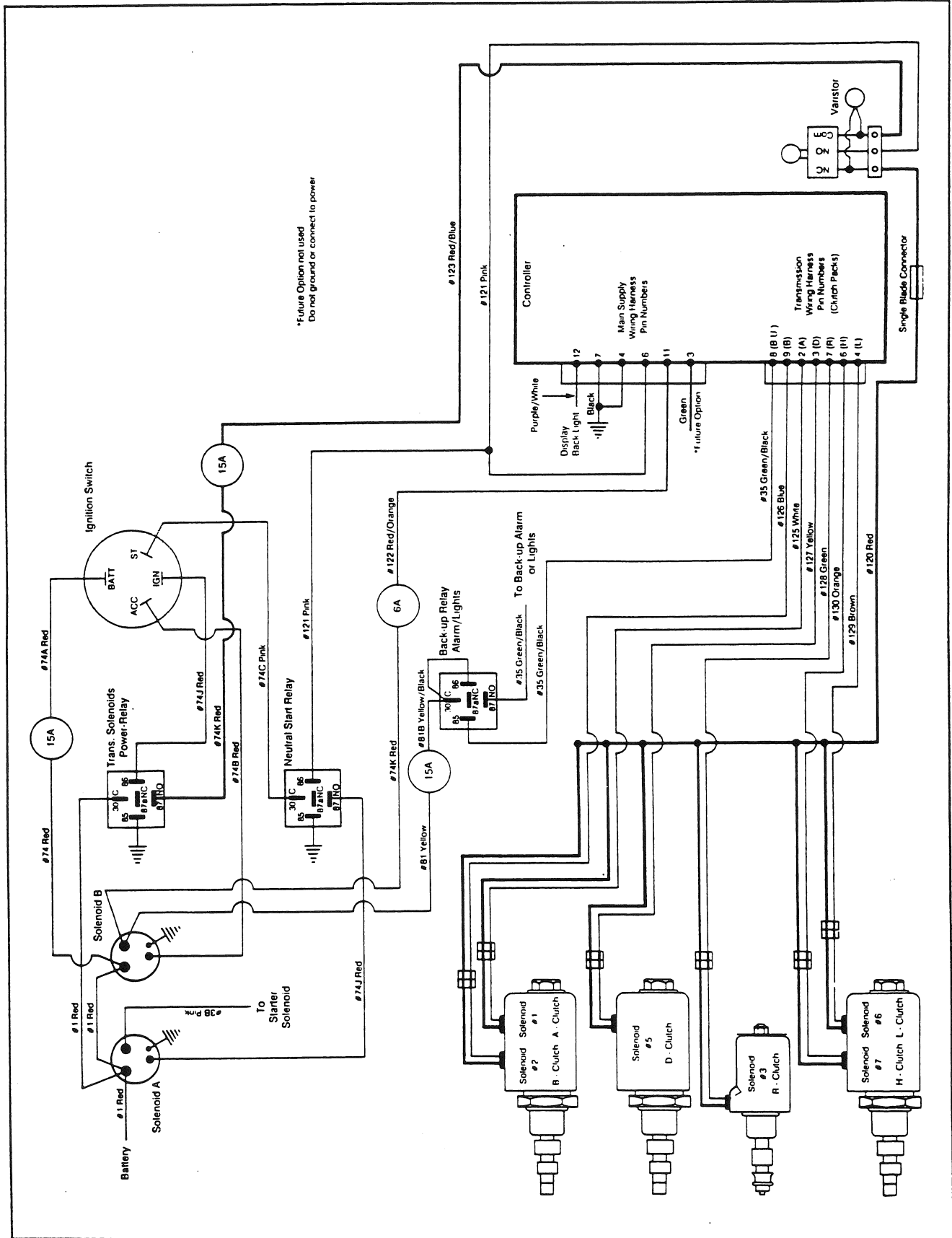

Electrical Schematic - Gearco Model 8400 Transmission S/N 21450 TO 24259

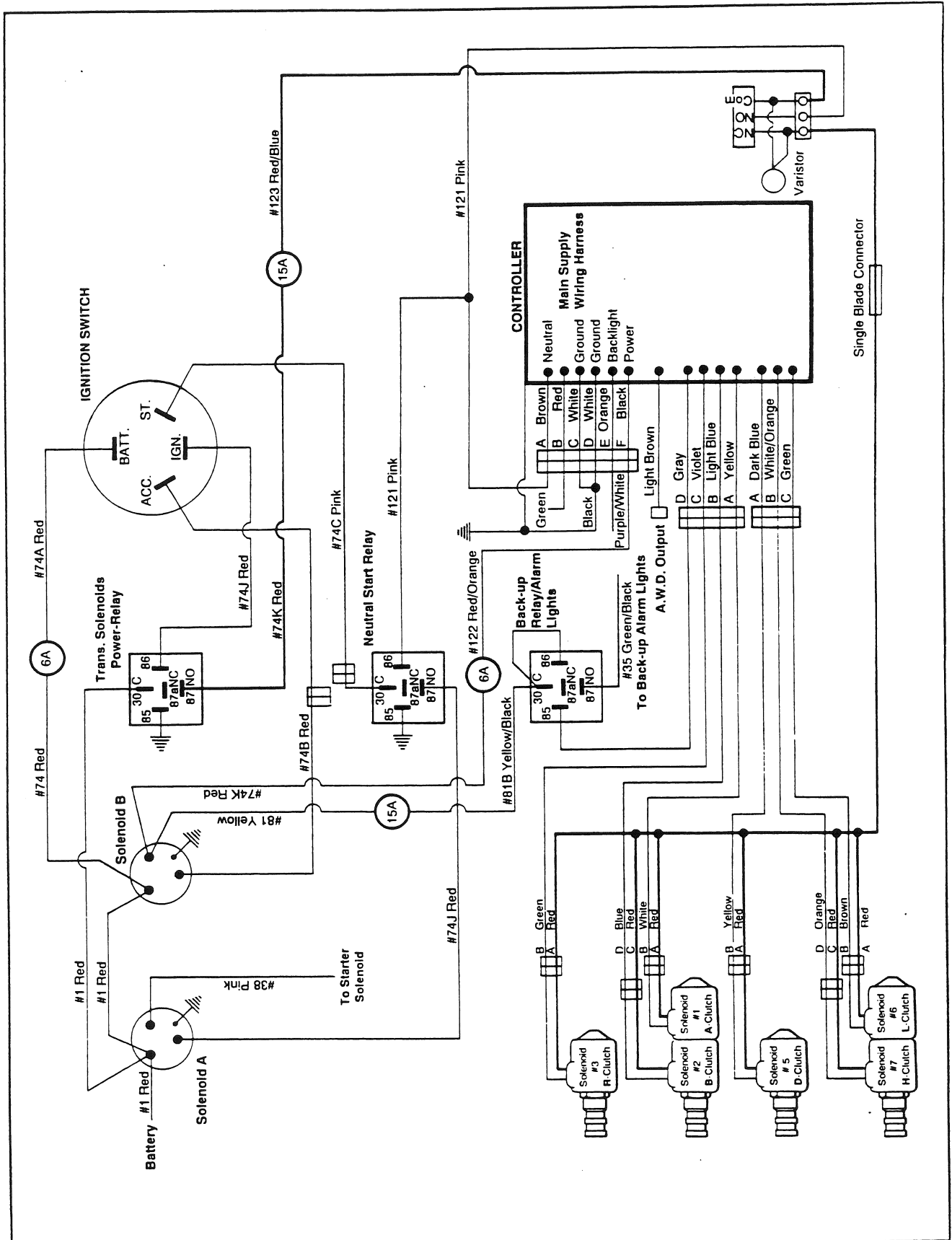

Solenoid/Clutch Engagement

SPEED	SOLENOIDS ENERGIZED	CLUTCH ENGAGED
1	1, 6	ACL
2	2, 6	BCL
3	1, 5, 6	ADL
4	2, 5, 6	BDL
5	1, 7	ACH
6	2, 7	BCH
7	1, 5, 7	ADH
8	2, 5, 7	BDH
Neutral	None	C
-1	3, 6	RCL
-2	3, 5, 6	RDL
-3	3, 7	RCH
-4	3, 5, 7	RDH

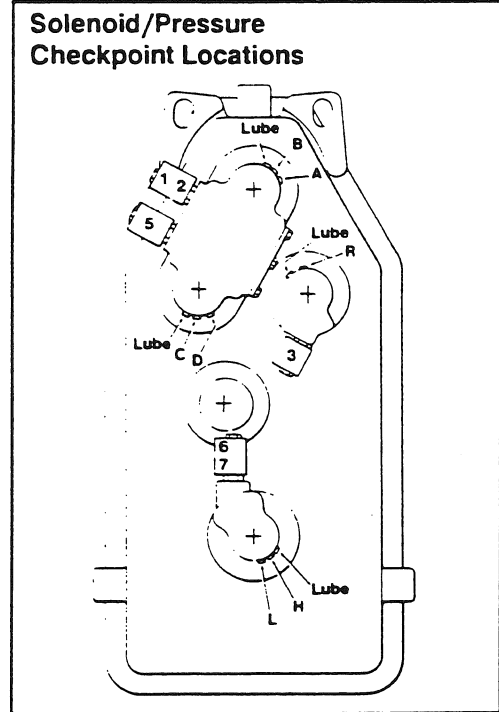

Solenoid Coil Resistance Values - approximate (12Vdc only) Up to S/N 21449

CLUTCH PACK	SOLENOID COIL	PART NUMBER	RESISTANCE VALUE (HIGH & LOW TOLERANCES)
Rev.	3	37107	8.6 to 8.1 ohms (Ω)
AB & LH	1/2 & 6/7	37105/56211	6.3 to 5.9 ohms (Ω)
D	5	37106	5.2 to 4.9 ohms (Ω)

Resistance should be measured at a temperature of 20°C (68°F). Refer to the table in Section 8, Page 5 of the 700 Series Shop Manual. Amend the figures in the table to those shown above.

Torque Specifications - Up to S/N 21449

APPLICATION	lbf.ft	N.m
AB, LH & D Valve Cartridges	30 - 40	41 - 54
Solenoid Retaining Nuts for above	5 - 6	6,8 - 8,1
R Valve Cartridge	16 - 20	22 - 27
Solenoid Retaining Nuts for above	3 - 4	4,1 - 5,4

Solenoid Coil Resistance Values - S/N 21450 TO 24259

SOLENOID COIL	PART NUMBER	RESISTANCE VALUE
12 Volt	58727	7.2 (Ω)
24 Volt	58728	28.8 (Ω)

Resistance at a temperature of 20°C (68°F).

Torque Specifications - S/N 21450 TO 24259

APPLICATION	lbf.ft	N.m
Solenoid Cartridges	25	33,9
Solenoid Retaining Nut	5	6,8

Grader will Operate

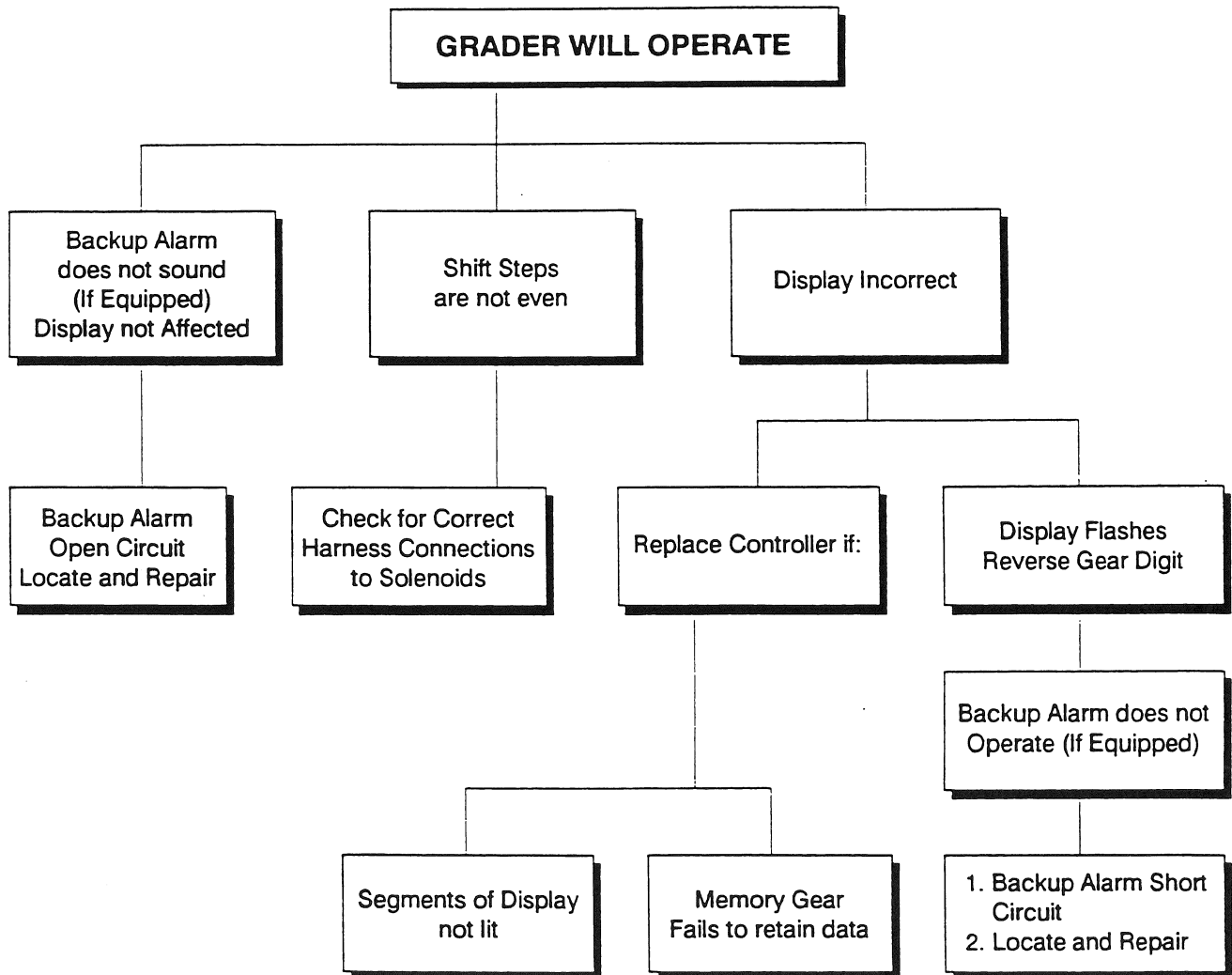

Notes